



## SOT-23 Plastic-Encapsulate Transistors

### A733LT1

TRANSISTOR (PNP)

#### FEATURES

Power dissipation

$$P_{CM}: 0.2 \text{ W (Tamb=25}^\circ\text{C)}$$

Collector current

$$I_{CM}: -0.15 \text{ A}$$

Collector-base voltage

$$V_{(BR)CBO}: -60 \text{ V}$$

Operating and storage junction temperature range

$$T_J, T_{stg}: -55^\circ\text{C to } +150^\circ\text{C}$$

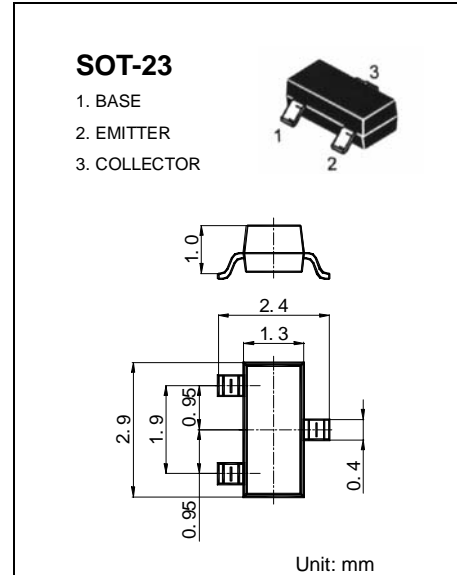

#### ELECTRICAL CHARACTERISTICS (Tamb=25°C unless otherwise specified)

Parameter	Symbol	Test conditions	MIN	TYP	MAX	UNIT
Collector-base breakdown voltage	$V_{(BR)CBO}$	$I_C = -5 \mu\text{A}, I_E = 0$	-60			V
Collector-emitter breakdown voltage	$V_{(BR)CEO}$	$I_C = -1 \text{ mA}, I_B = 0$	-50			V
Emitter-base breakdown voltage	$V_{(BR)EBO}$	$I_E = -50 \mu\text{A}, I_C = 0$	-5			V
Collector cut-off current	$I_{CBO}$	$V_{CB} = -60 \text{ V}, I_E = 0$			-0.1	$\mu\text{A}$
Emitter cut-off current	$I_{EBO}$	$V_{EB} = -5 \text{ V}, I_C = 0$			-0.1	$\mu\text{A}$
DC current gain	$H_{FE(1)}$	$V_{CE} = -6 \text{ V}, I_C = -1\text{mA}$	120		475	
Collector-emitter saturation voltage	$V_{CE(sat)}$	$I_C = -100\text{mA}, I_B = -10\text{mA}$		-0.18	-0.3	V
Transition frequency	$f_T$	$V_{CE} = -6 \text{ V}, I_C = -10\text{mA}$ $f = 30\text{MHz}$	50			MHz

#### CLASSIFICATION OF $H_{FE(1)}$

Rank	L	H
Range	120-200	200-475
MARKING	CS	